

CE 0786 09	DOP-IFD176 ESMI22051E	EN 54-7: 2018	Schneider Electric Buildings AB Mobilvägen 8, 223 62 Lund, Sweden
	DOP-IFD177 ESMI22051EI	EN 54-17: 2005 (EI only)	

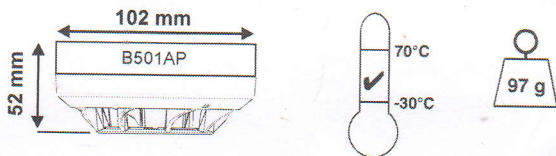

ENGLISH

**INSTALLATION AND MAINTENANCE
INSTRUCTIONS FOR MODEL ESMI22051E(I)
PHOTO ELECTRONIC SMOKE SENSOR**

GENERAL DESCRIPTION

Models ESMI22051E and ESMI22051EI are intelligent plug-in type smoke sensors that combine a photoelectronic sensing chamber with addressable communications. These sensors are designed for open area protection and must only be connected to control panels that use a compatible proprietary communication protocol for monitoring and control.

The ESMI22051EI sensor contains an isolator, if installing this version check the panel documentation for details of how many isolators can be used on a loop.

Two LEDs on each sensor light to provide a local 360° visible sensor indication (operation of LEDs are dependent on panel). Remote LED indicator capability is available as an optional accessory wired to the standard base terminals (again dependent on panel).

SPECIFICATIONS

Operating Voltage Range: see S00-7300
 Max. Standby Current (no comm.): 200 µA @24 V and 25°C
 (comm. LED blink enabled - 5 sec) 300 µA @24 V and 25°C
 (Read 16 sec. LED blink 8 sec) 220 µA @24 V and 25°C
 add 50 µA for ESMI22051EI Isolated
 Max. Alarm Current (LED on): 3.5 mA @ 24 V and 25°C
 Operating Humidity Range: 10% to 93% Relative Humidity, Non-Condensing

Isolator Characteristics (ESMI22051EI Only): see S00-7300
 Independently tested and certified to: EN 54-7: 2018 (and EN 54-17: 2005 for EI)

WIRING GUIDE

Refer to the installation instructions supplied with the plug-in sensor bases for wiring details. All bases are provided with terminals for power and an optional Remote Indicator.

Note 1: All wiring must conform to applicable local and national codes and regulations.
Note 2: Verify that all sensor bases are installed and that polarity of the wiring is correct at each base.

WARNING

Disconnect loop power before installing sensors. Notify proper authorities.

SENSOR INSTALLATION

1. Set the sensor address (see figure 1) by turning the two rotary switches on the underside of the sensor, selecting a number between 01 and 159. (Note: The number of addresses available will be dependent on panel capability, check the panel documentation for information on this). Record the address on the label attached to the base.

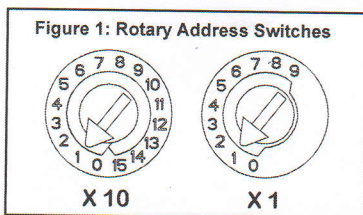

2. Insert the sensor into the base and rotate it clockwise until it locks into place.
3. After all the sensors have been installed, apply power to the system.
4. Test the sensor as described under TESTING.
5. Reset the sensor by communication command from the panel.

Tamper-Resistance.

These sensors includes a feature that, when activated, prevents removal of the sensor from the base without the use of a tool. Refer to the installation instructions for the sensor base for details of how to use this feature.

CAUTION

Dust covers help to protect units during shipping and when first installed. They are not intended to provide complete protection against contamination therefore sensors should be removed before construction, major re-decoration or other dust producing work is started. Dust covers must be removed before system can be made operational.

Figure 2: Cleaning the Sensor

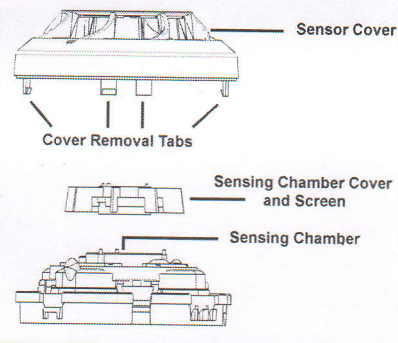

MAINTENANCE

Before cleaning, disable the system to prevent unwanted alarms:

1. Remove the sensor to be cleaned from the system.
2. Gently release each of the four cover removal tabs that hold the cover in place (see figure 2) and remove the sensor cover.
3. Vacuum the outside of the screen/chamber cover carefully without removing it.
4. Remove the screen/chamber cover assembly by pulling it straight out.
5. Use a vacuum cleaner and/or clean, compressed air to remove dust and debris from the sensing chamber and sensing chamber cover.
6. Re-install the sensing chamber cover by aligning the square and round holes on the cover with the square and round pins around the sensing chamber, gently pressing it home until it slips into place (Note: Arrows on the plastic indicate the positioning when replacing the chamber cover and air guide).
7. Re-install the sensor cover. Use the cover removal tabs and LEDs to align the cover with the sensor. Snap the cover into place.
8. When all sensors have been cleaned, restore power to the loop and test the sensor(s) as described under TESTING.

TESTING

Sensors must be tested after installation and following periodic maintenance. Disable the zone or system undergoing maintenance to prevent unwanted alarms.

Test the sensors as follows:

Magnet Method

1. Test the sensor by positioning the test magnet (model M02-04-00 optional) against the sensor body approximately 2 cm from LED 1, indicated by a mark on the sensor cover as shown in figure 3.
2. Both LED's on the sensor should latch into alarm within 30 seconds, activating the control panel.

Figure 3: Test Magnet Position

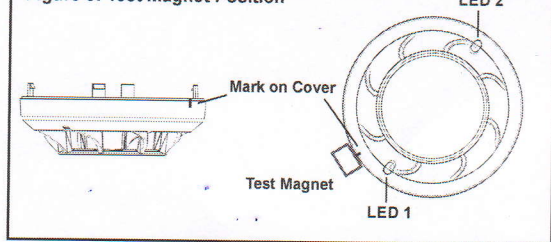

Smoke Method

1. Using generated smoke, or synthetic smoke aerosol from an approved manufacturer such as No Climb Products Ltd, subject the sensor to controlled amounts of smoke in accordance with local codes of practice and manufacturer recommendations.
2. Both LED's on the sensor should latch into alarm within 30 seconds, activating the control panel.

After completion of the test notify the proper authorities that the system is operational.

WARNING

LIMITATIONS OF SMOKE SENSORS

Smoke sensors must be used in conjunction with compatible equipment. Smoke sensors will not sense fires which start where smoke does not reach the sensors. A sensor may not detect a fire developing on another level of a building. Smoke sensors also have sensing limitations. Consideration must be made of the environment when selecting fire sensors.

Smoke sensors cannot last forever. Smoke sensors contain electronic parts. Even though sensors are made to last over 10 years, any of these parts could fail at any time. Therefore, test your smoke detection system at least semi-annually. Clean and take care of your smoke sensors regularly. Taking care of the fire detection system you have installed will significantly reduce your product liability risks.

Safety Information

Electrical equipment should be installed, operated, serviced, and maintained only by qualified personnel. No responsibility is assumed by Schneider Electric for any consequences arising out of the use of this material. A qualified person is one who has skills and knowledge related to the construction, installation, and operation of electrical equipment and has received safety training to recognize and avoid the hazards involved.